

CAD data: MR6000A040\_02\_Outline Drawing

寸法許容差 Tolerance (±mm) 上 A				材質 Material	処理 Finish
UP TO 4	0.1	OVER 63 UP TO 250	0.3	—	—
OVER 4 UP TO 16	0.1	OVER 250 UP TO 1000	0.5	2	2018/06/26 松村敏浩
OVER 16 UP TO 63	0.2	角度 ANGLE	±0.5°	初版 Orig.	2017/04/27 富山英樹
				履歴 Sym.	YYYY/MM/DD 日付 Date
					設計 Designed by
					注記 Description

承認 Approved by		投影法 Projection Method	形名 Model
増田耕一		第一角法	MR6000
検査 Checked by		尺度 Scale	単位 Unit
戸井 順		1:2	mm
設計 Designed by フルネーム		シート Sheet	シートサイズ Sheet Size
松村敏浩		1 / 2	A2
名称 Title		図番 Draw No.	
Outline Drawing		MR6000A040	
		版 Rev.	02

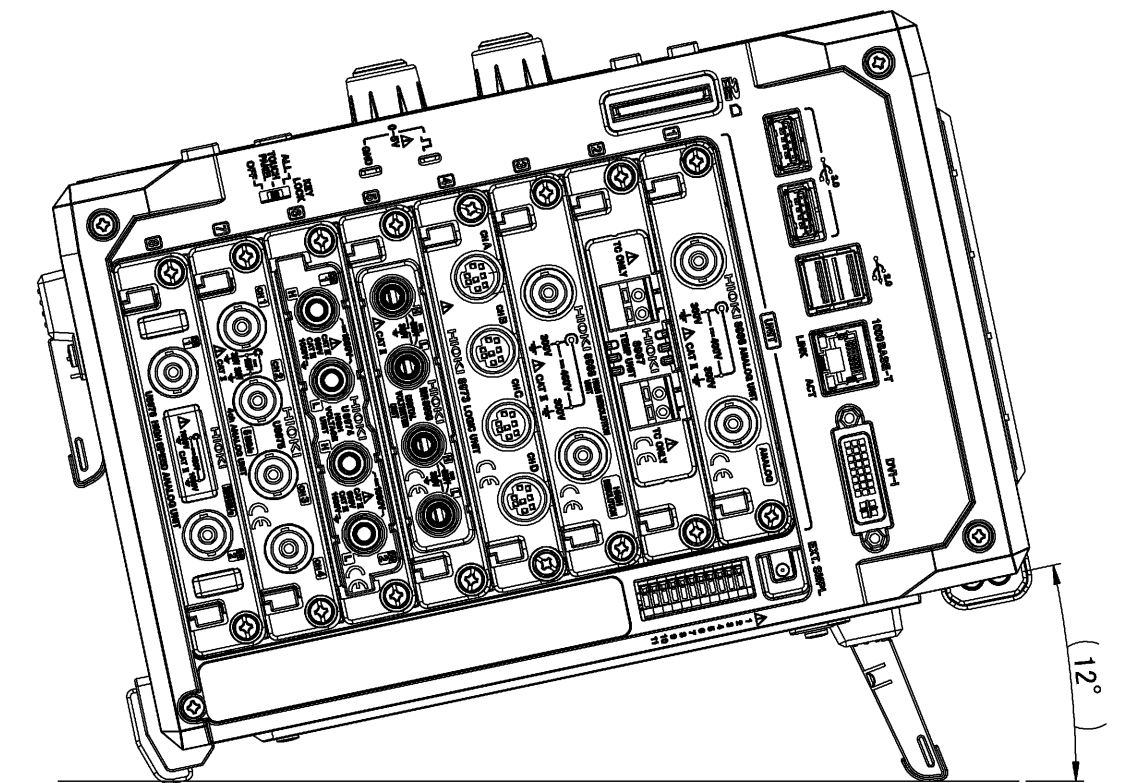
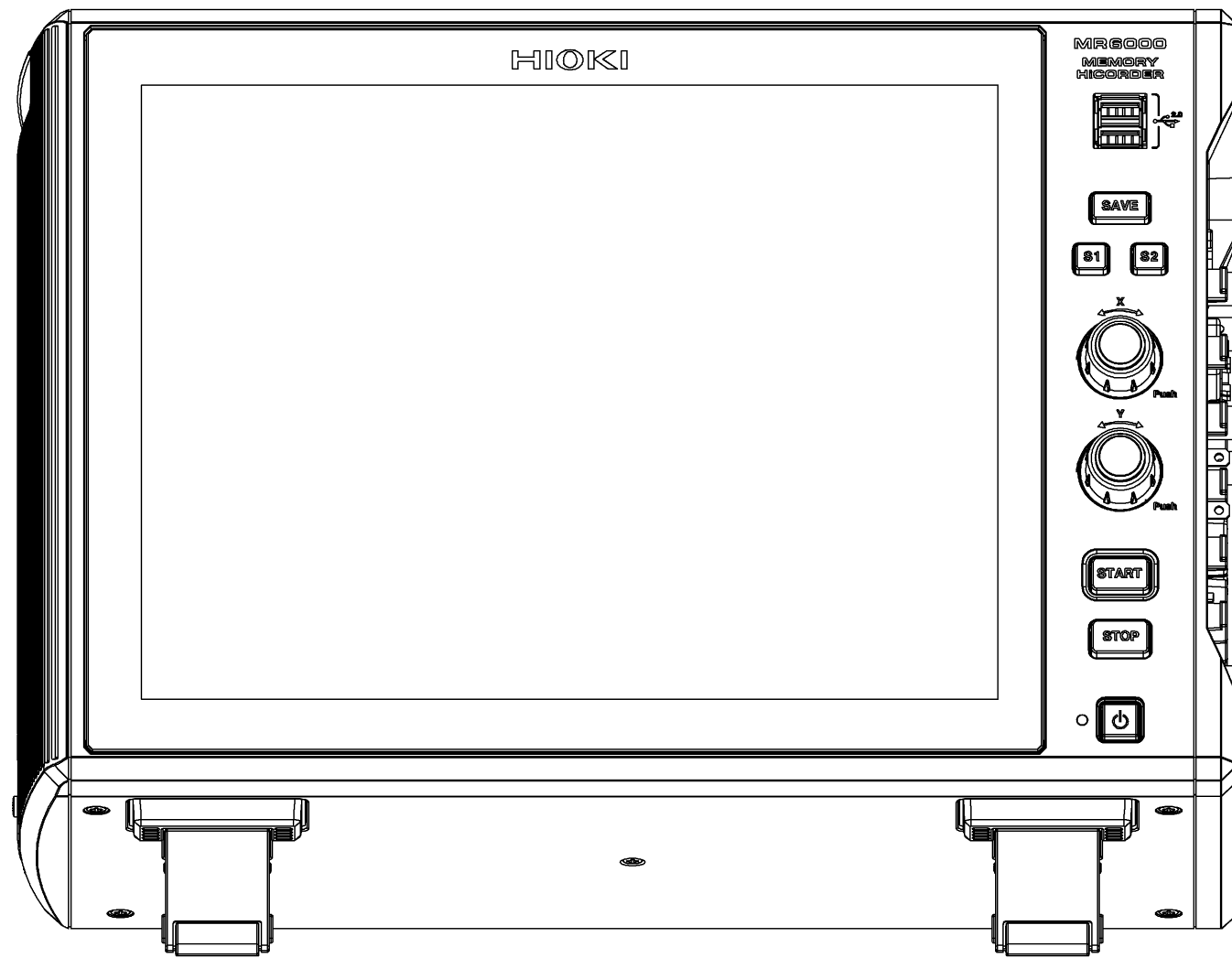
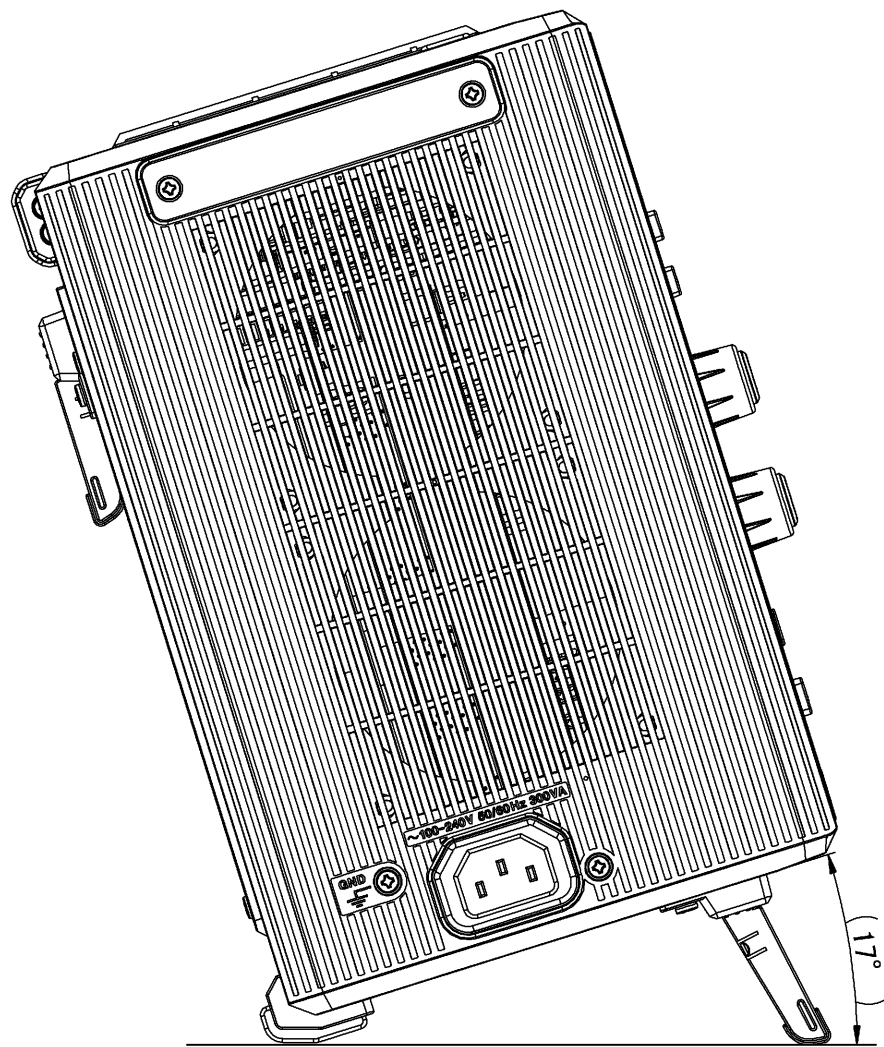
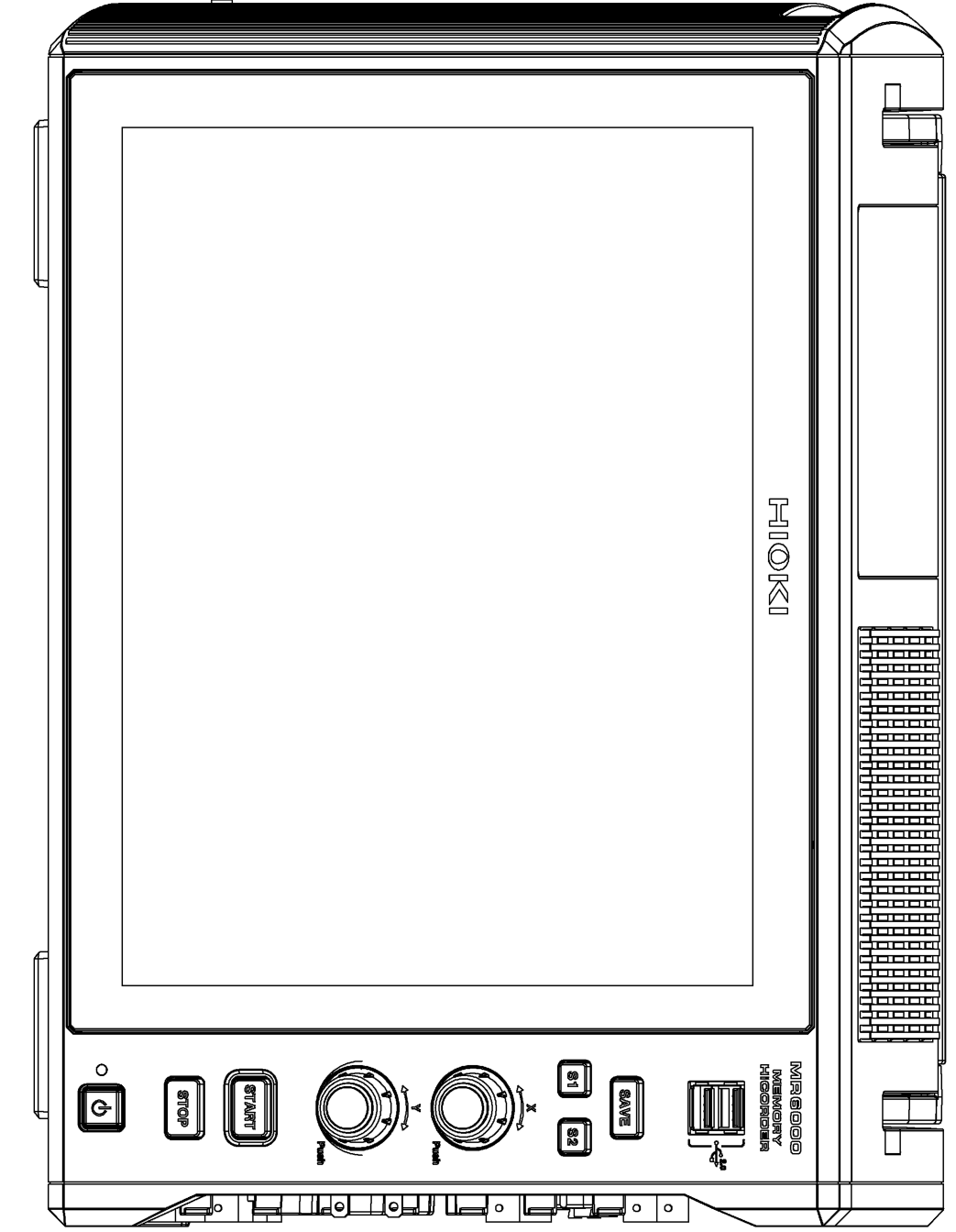
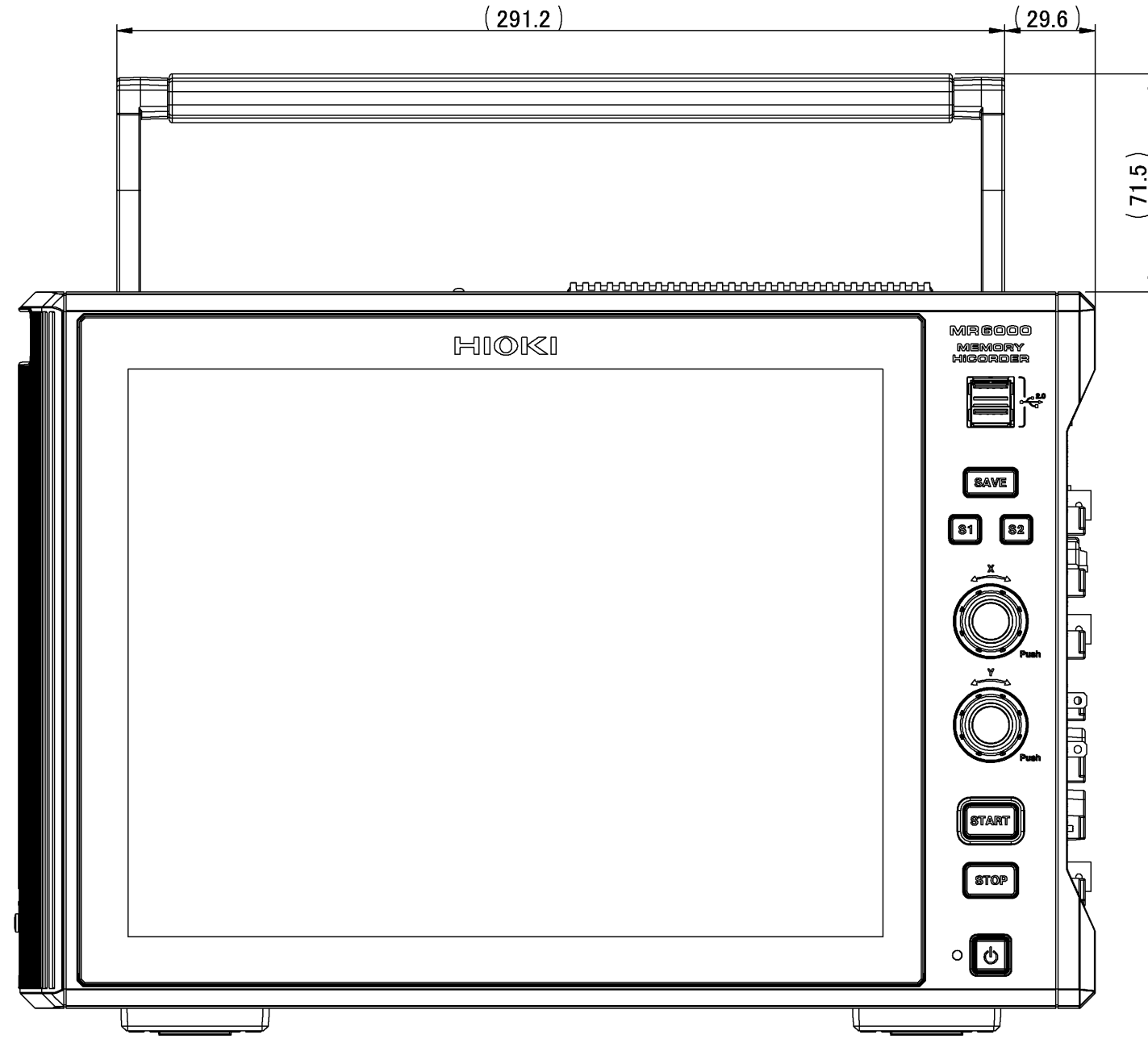
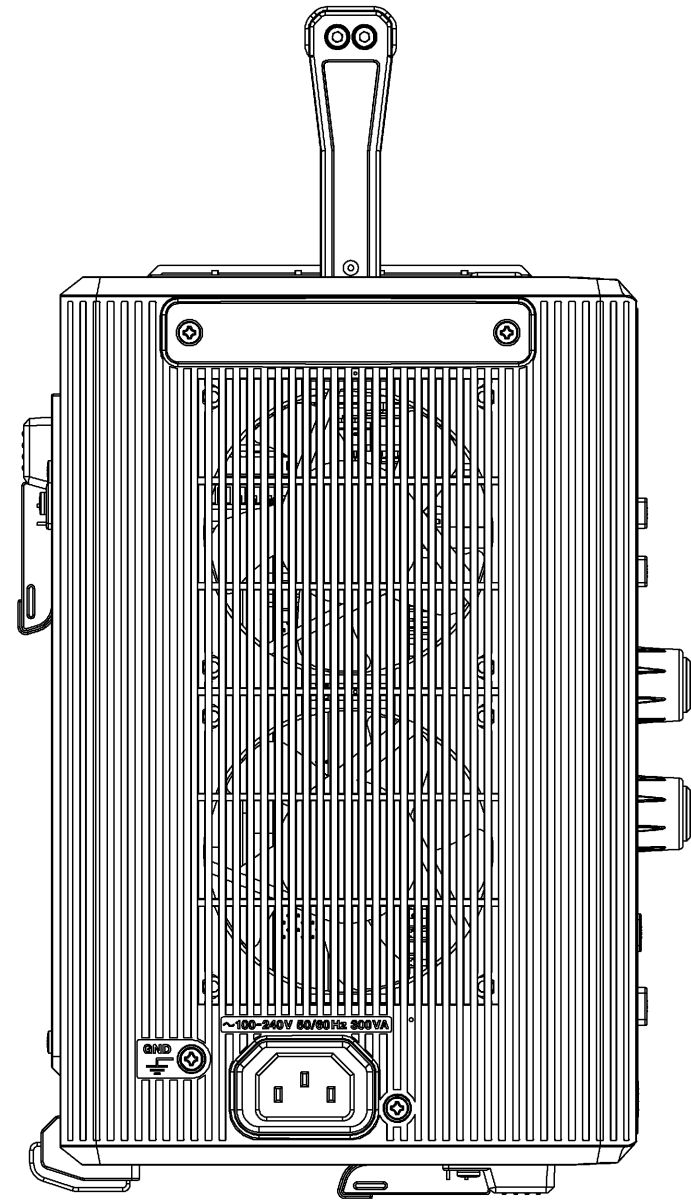

寸法許容差 Tolerance (±mm) 上 A				材質 Material			
UP TO 4	0.1	OVER 63 UP TO 250	0.3	処理 Finish	-		
OVER 4 UP TO 16	0.1	OVER 250 UP TO 1000	0.5	初版 Orig.	2018/06/26	松村敏浩	形名ラベル削除、製造ラベル変更
OVER 16 UP TO 63	0.2	角度 ANGLE	±0.5	履歴 Sym.	2017/04/27	富山英樹	新規作成
				履歴 Date	YYYY/MM/DD	設計 Designed by	注記 Description

CAD data: MR6000A040_02_Outline Drawing			
承認 Approved by	増田耕一	投影法 Projection Method	形名 Model MR6000
検査 Checked by	戸井 順	尺度 Scale	単位 Unit
設計 Designed by	フルネーム 松村敏浩	1:2	mm
シート Sheet	2 / 2	シートサイズ Sheet Size	A2
名称 Title	Outline Drawing		図番 Draw No. MR6000A040
版 Rev.	02		